

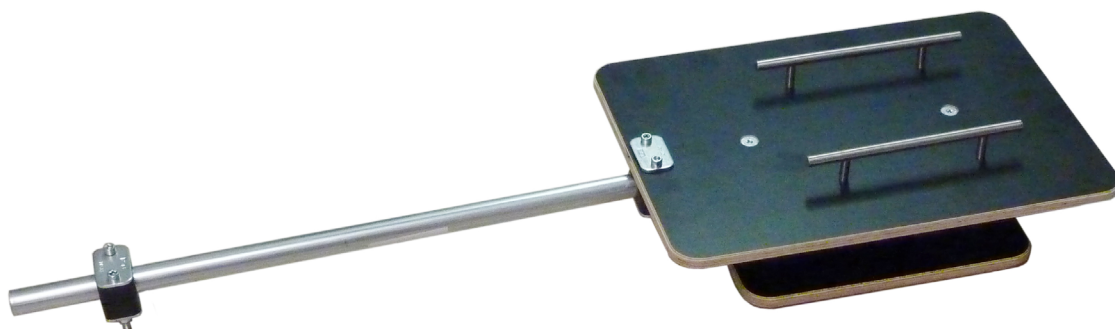

## Handleiding kanteltafel Manual rocking table ref. CB-RT2

Te gebruiken in combinatie met Coplate CBXX-20F2  
To be used in combination with Coplate CBXX-20F2



Benodigd gereedschap  
Tools required

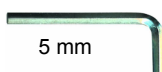

5 mm



SW 10



















PZ

De informatie en gegevens in deze handleiding kan zonder voorafgaande kennisgeving worden gewijzigd.  
Geen enkel deel van deze handleiding mag worden veeelvoudigd in enige vorm of op enige wijze zonder de schriftelijke toestemming van de BIKEACCES.  
The information and data given in this user manual can be changed without prior notice.  
No part of this manual may be reproduced in any form or by any means without the written permission of the BIKEACCES 17-09-2019

# Inhoud ref. CB-RT2

## Contents ref. CB-RT2

	Aantal Qty.	Ref	Omschrijving Description	Afbeelding Picture	
1	2x	14006	Inbuschroef / Screw M8x40		
	2x	14013	Vulstuk / Spacer i.d. 8mm, H=25mm		
	4x	14016-1205	Zelfklevend voet / Adhasive foot Ø12mm, hoog 5 mm		
	4x	14027	Flensmoer / Flange nut M6		
	1x	14030	Waterpas / Bubble level		
	4x	14056	Stalen plaat / Steel plate		
	2x	140022	Beugel / Clamp Ø22		
			140660	Inbusbout / socket screw M6 L=60	
	4x	14047	Sticker voor voorwielsteun / Sticker for frontwheel riser Ø 30mm		
2	2x	14014	Rubber / Rubber M8 Ø40 H=30mm		
	2x	140036	Steun / Support 10x128mm		
	4x	140036-20	Schroef / Screw M4x20		
	2x	140661-20	Bolkopflensbout M8x20		
3	1x	14044	Buis / Tube Ø22 L=63 cm		
4	1x	140032-B12	Multiplex plaat / Ply wood plate 27x27x1,2 cm		
5	1x	140033-B12	Multiplex plaat / Ply wood plate 29x41x1,2 cm		

**CB-RT2 onderplaat**  
Plaats zelfklevende voetjes

**CB-RT2 bottom plate**  
Position adhesive feet

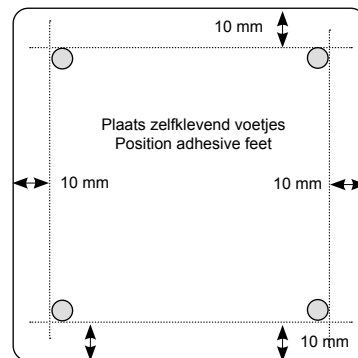
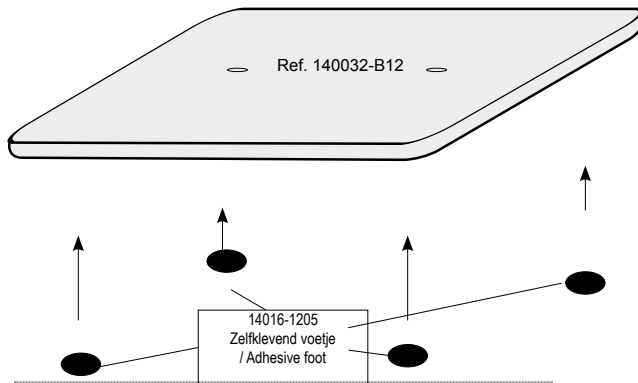

# Montage Assembling

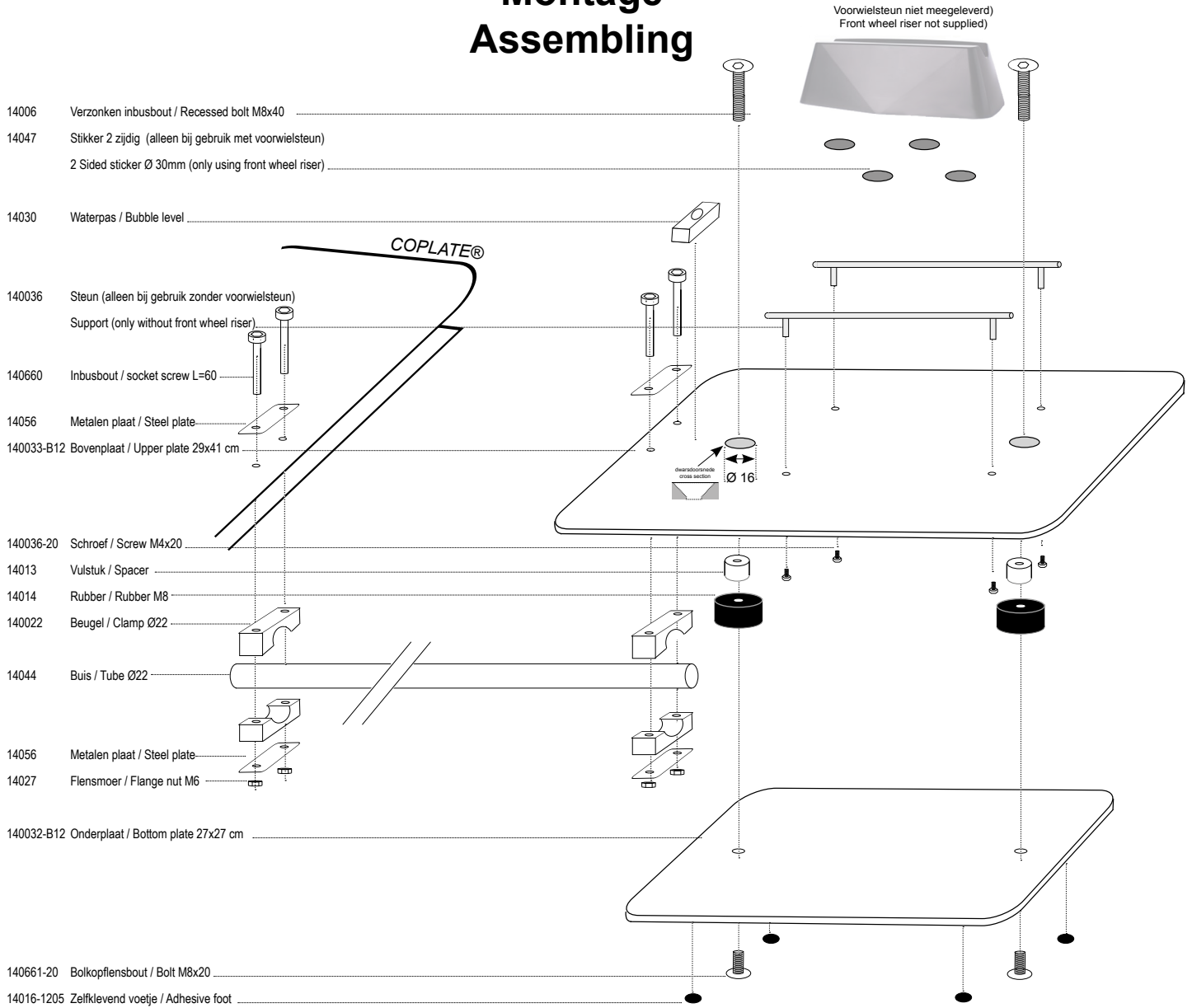

## Volgorde assemblage kantelafel:

1) Monteer de twee steunen 140036 met schroeven 143006-25 evenwijdig aan de hartlijn op de bovenplaat 140033-B12 en wel zodanig dat de voorband wat speling heeft.

**Opmerking:** Monteer de 2 steunen 140036 alleen als er **GEEN** voorwielsteun wordt gebruikt.

2) Monteer in de bovenplaat de verzonken inbusbouten 14006 samen met vulstuk 14013, rubber 14014 en bolkopflenskantbout 140661-20

3) Monteer beugels 140022, inbusbouten 140660, ringen 14004, metalen plaatjes 14056 en flensmoeren 14027 op de bovenplaat 140033-B12, zet de moeren **NIET** volledig vast.

4) Plak de zelfklevende voetjes 14016-1205 op de onderzijde van de onderplaat 140032-B12.

5) Monteer beugels 140022, inbusbouten 140660, ringen 14004, metalen plaatjes 14056 en flensmoeren 14027 op de COPLATE®, zet de moeren **NIET** volledig vast.

6) Plaats de buis 14044 in de beugels 140022.

7) Positioneer de kantelafel, zie stap 2 op pag. 4.

8) Volg de montageschappen 1 t/m 3 op pag. 4 en zet alle inbusbouten 140660 volledig vast.

## Sequence assembly rocker table:

1) Install the two brackets 140036 with screws 143006-25 parallel to the centerline on the top plate 140033-B12 so that the front tire has some space.

Note: Mount only the 2 supports 140036 if a front wheel riser will **NOT** be used.

2) Mount in the upper plate the recessed bolts 14006 together with spacer 14013, rubber 14014 en bolt 140661-20

3) Mount clamps 140022, socket screws 140660 rings 14004, metal plates 14056 and flange nuts 14027 on the upper plate 140033-B12, **DO NOT** tighten fully the screws.

4) Put the adhesive feet 14016-1205 on the under side of the bottom plate 140032-B12.

5) Mount clamps 140022, socket screws 140660, rings 14004, metal plates 14056 and flange nuts 14027 on the COPLATE®, **DO NOT** tighten fully the screws.

6) Put the tube 14044 in the clamps 140022.

7) Position the rocker table, see step 2 on page. 4.

8) Follow the steps 1 up to 3 on pag. 4 and tighten fully all the socket screws 140660.

# Montage kantelafel CB-RT2- Mounting rocker table CB-RT2

1

Fietstrainer  
Cycle trainer

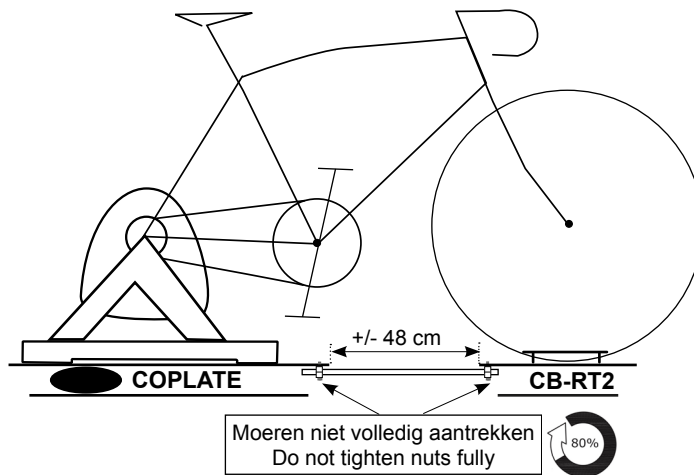

2

Bovenaanzicht - Upper view

Wahoo Kickr of/or Wahoo Kickr Core

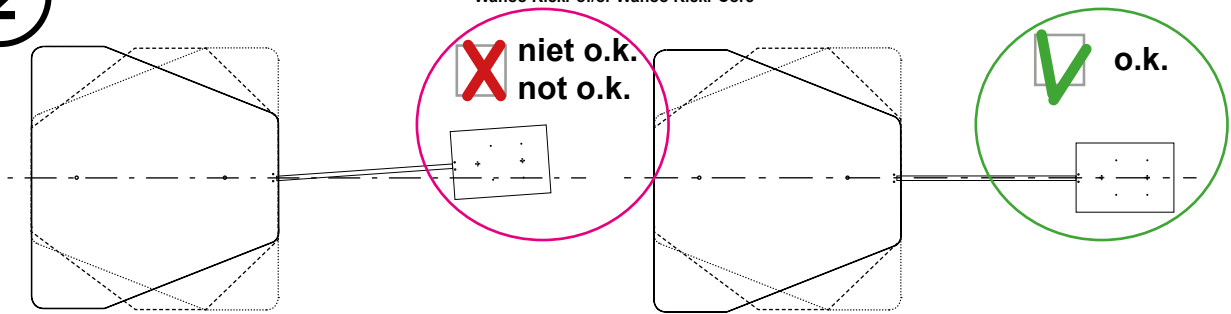

3

Bovenaanzicht - Upper view

Wahoo Kickr of/or Wahoo Kickr Core

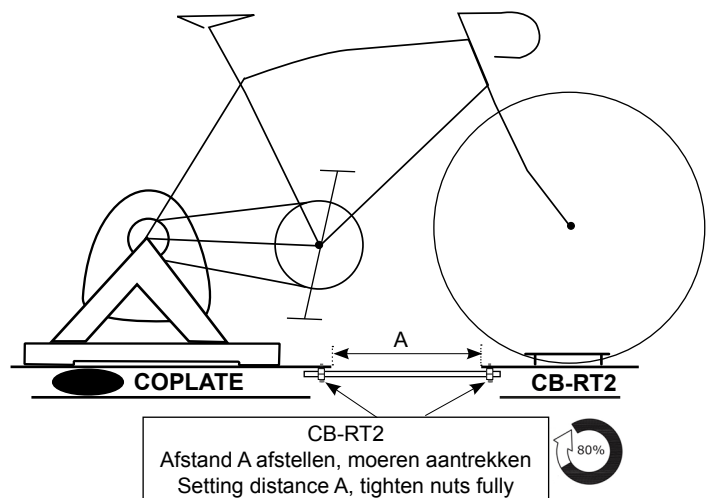
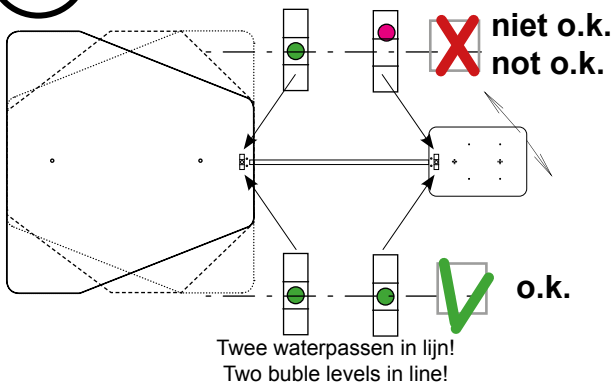

**Indien de twee gaten in de tekening hieronder niet aanwezig, dient men deze te boren.**  
**If the two holes in the drawing below are not present, they have to be drilled.**

Benodigd gereedschap  
Tools required



Ø 6,5 mm



Tip:

Gebruik stalen plaat ref. 14056 als boormal, zie pag. 2  
Use steel plate ref. 14056 as drilling guide, see page 2

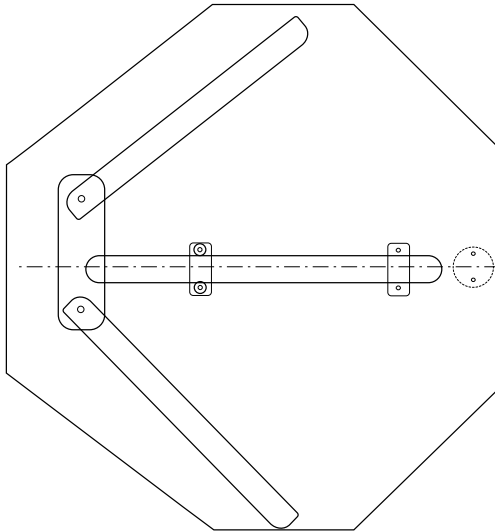
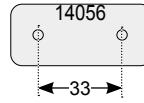

Wahoo Kickr  
Elite Direto X  
Elite Suito

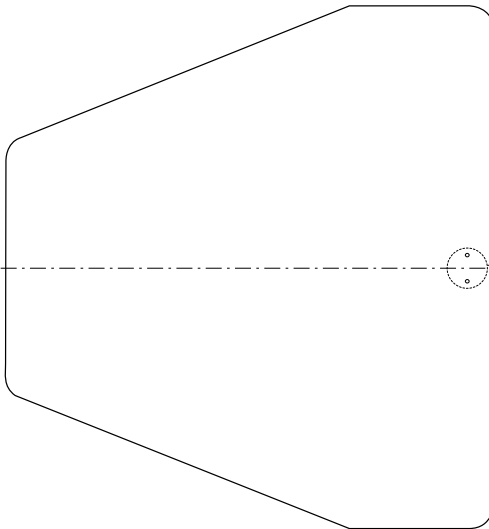
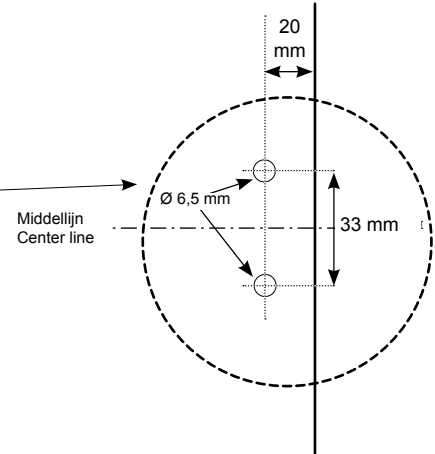

Tacx: Flux, Genius, i-Vortex, Ironman, Bushido, Booster, Satori, FLOW, Blue serie.

Wahoo Kickr Core Wahoo Kickr Snap,  
BKOOOL en Elite Drivo

Kinetic Road Machine  
Thinkrider A1, Thinkrider X3 Smart Pro

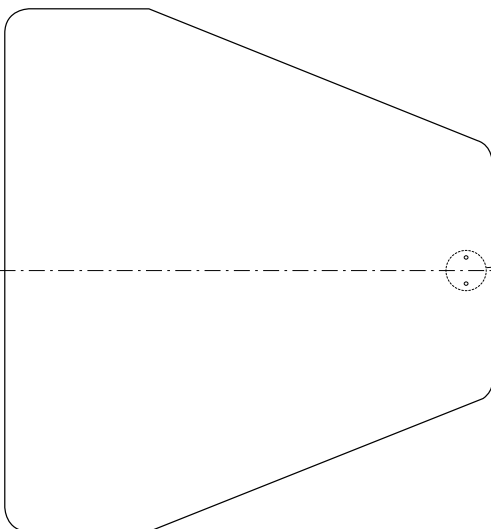
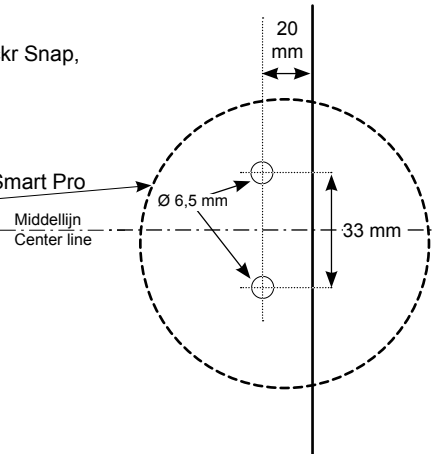

Tacx Neo

